

Tech Sheet: Agusta MH-68A, Sting Ray

(agusta-MH68.pdf)



Agusta 109 Mk II+ Bubble Cover and Blade Tie-downs

Section 1: Cockpit/Bubble Covers

The **Agusta MH-68A, Sting Ray Bubble Cover** helps reduce damage to the upholstery and avionics caused by excessive heat and can eliminate problems caused by leaking door and window seals. They keep the windshield and window surfaces clean and help prevent vandalism and theft.

The **Bubble Cover** encloses the entire canopy including the windshield, skylights, and chin bubble. Attachment buckles are made of nonmetal *Delrin*, designed for rugged outdoor use. Both the top and bottom hems of the cover have a special rope-hem feature with which they can be tightened to help prevent abrasive chafing of the windshield. Pockets are sewn into the cover for the temperature probe and pitot tubes. The bubble cover is reinforced with patches at hinge points, door handles, and for the windshield wipers. For ease of installation, the bubble cover is color-coded (red=left, green=right) with color swatches sewn into the corners.

This cover type is made from Silver Acrylic Sunbrella canvas and is 100% lined with a soft and smooth microfiber. Bruce's Custom Covers developed this material combination especially for aircraft protection. The outer material is medium weight and treated for water resistance, UV resistance and anti-static buildup. The inner lining is a very soft and smooth microfiber to prevent scratching. The material is very reflective, and tests show that the cabin interior temperature can be reduced to near-ambient temperature on the hottest of days. It is water, ice and snow repellent, yet breathable to allow moisture to escape from between the cover and the aircraft surface.



Koala Bubble, Rotor Hub, Blade & Tail Rotor Covers (illustration)



Agusta Grand Bubble Cover

Description	Part Number	Price
BUBBLE COVER	MH68-000	Contact Us
BUBBLE COVER w/Wire Strike	MH68-010	Contact Us
WINDSHIELD COVER	MH68-015	Contact Us

Section 2: Engine/Tail Rotor Covers

Blade Tie-Downs are "socks" which fit over the blade tip with or without Blade Covers installed. Front blade tie-downs have two lengths of rope or strap which attaches to the front cross tubes on either side of the cabin. The other tie-downs have generous lengths of rope or strap to tie the blades down at any convenient spot.

Engine Cover details vary by model, but generally these covers are designed to enclose and protect the swash plate, inlet, exhaust and engine access areas. They are designed to tighten up around the main rotor drive shaft and tailboom bottleneck areas, and attach securely with straps either under the belly or to the land gear cross tubes (or both). *Delrin* buckles are used to tighten the attachment straps. The engine cover is made of Solution-Dyed Polyester or acrylic *Sunbrella*, and is available in a variety of colors ([contact us for details]/(contact)). Specific information for each model is available on request.

Rotor Hub Covers overlaps with the Blade Covers to ensure complete protection for the entire main rotor system. Designed like a jacket with sleeves and no collar, the rotor hub cover fastens together below each blade with *Delrin* buckles. The Rotor Hub Cover is normally made from Solution-Dyed Polyester.

Bruce's **Agusta MH-68A, Sting Ray Blade Covers** are made of medium-weight Solution-Dyed Polyester and designed to avoid trim tabs or wicks. You can install Blade Covers from the ground with the aid of a lightweight rope attached to the open end. Covers are cinched tight at the blade root with straps and quick-release plastic buckles. The **Cold Weather Blade Covers** are fitted with full-length zippers and optional deice "boots" designed to accept a preheater hose; a small opening at the tip of the cover allows for some air circulation and drainage in freezing weather. Some part numbers have features for an extra charge.

The **Agusta MH-68A, Sting Ray Insulated Engine Cover** works well in cold climates to help with engine preheating. You can add an access flap for an additional fee. It will cinch around or behind the spinner, cover the entire engine cowl area including the engine air inlets, and fastens together with Velcro beneath the spinner down the front of the cowling.

Insulated Covers Material - A special composite material of solution-dyed polyester, 3M Thinsulate insulation, and soft nylon interior fabric. Our insulated covers are designed to complement an engine preheater and help retain heat in the engine compartment after shutdown. If you operate your aircraft in cold-weather, these covers will help prevent engine wear and tear.

The **Agusta MH-68A, Sting Ray Intake Cover**. Details vary by model, but generally helicopter intake covers are designed to enclose the intake area only. They are smaller than helicopter engine covers, and their attachment details can vary from straps, to snaps, or some combination of the two. Specific information for each model is available on request.

The **Agusta MH-68A, Sting Ray Tail Rotor Cover** is a one-piece design which encloses both the blades and their hub, snapping

closed along the bottom edge. The tail rotor cover is normally made from Solution-Dyed Polyester.

ALL-YEAR USE MATERIAL - Made with Silver Acrylic Sunbrella canvas, the all-year use material is the best option for sun protection and cover longevity. This heavier more durable material is intended for all weather conditions, such as rain and snow or lots of sun.

WINTER USE MATERIAL - Made with Solution-Dyed Polyester fabric, this option is intended for seasonal use to aid in deicing, rain mitigation, or for occasional travel. The material is lighter and more compact, but more susceptible to UV damage and may have a shorter useful life if used continuously outside than the all-year use material.



Agusta Power Pitot Covers, Intake Covers, and Cockpit Heatshield set



Agusta Power Engine Cover (illustration)

Description	Part Number	Price
ENGINE COVER	MH68-100	Contact Us
INSULATED ENGINE COVER	MH68-105	Contact Us
ROTOR HUB COVER	MH68-200	Contact Us
BLADE TIE-DOWNS (fabric type) (set of 4)	MH68-210	Contact Us
BLADE COVERS (set of 4)	MH68-300	Contact Us
BLADE COVERS (COLD WEATHER TYPE) (set of 4)	MH68-301	Contact Us
TAIL ROTOR COVER	MH68-400	Contact Us
INTAKE COVERS, snap on type (set of 2)	MH68-500	Contact Us
EXHAUST COVERS, attaches to Intake Covers (set of 2)	MH68-600	Contact Us

Section 3: Plugs & Protection

Agusta MH-68A, Sting Ray Heat Resistant Pitot Tube Covers, are made of Naugahyde vinyl, and lined with a non-burning material. They are designed to cover the entire pitot assembly, slipping over the tube and tightening around the base with a Velcro strap detail. A "Remove Before Flight" streamer is attached to the cover. **Heat Resistant Pitot Covers** are an upgrade to our standard design, and help prevent the pitot cover from melting onto the tube if the pitot heat is accidentally turned on while installed. If you want the set tethered together, please let us know.

Agusta MH-68A, Sting Ray Pitot Tube Covers, NOT HEAT RESISTANT TYPE, are made of Naugahyde vinyl, and are designed to cover the entire pitot assembly. Slipping over the tube, the cover tightens around the base with a Velcro strap detail. A "Remove Before Flight" streamer is attached to the cover. **Heat Resistant Pitot Covers** are an upgrade to this design, and help prevent the pitot cover from melting onto the tube if the pitot heat is accidentally turned on while installed. If you want the set tethered together, please let us know.

The **Engine Inlet Plugs** are custom fit for your Agusta MH-68A, Sting Ray intakes, made with heavy-duty vinyl material, and stuffed

with a single block of sculpted urethane foam. Each plug has a zipper that allows the foam to be removed and dried if necessary. Engine plugs have 'Remove Before Flight' streamers sewn onto the face of the plugs. Most plugs are imprinted with the aircraft registration number in black for an extra charge. Storage bag NOT included. Engine plugs may be inserted after flight when the engine is still warm. Engine Inlet Plugs are commonly referred to as Cowl Plugs, Intake Plugs, Cowl Blocks, Engine Blocks, and Engine Bunges.



Agusta AW109 (A, C, & Trekker) Pitot Cover Set



Agusta Power Pitot Covers, Intake Covers, and Cockpit Heatshield set

Description	Part Number	Price
PITOT COVER SET (set of 2)	MH68-550	Contact Us
PITOT COVER SET, heat resistant type (set of 2)	MH68-551	Contact Us
SWASH PLATE PLUG	MH68-700	Contact Us

Section 5: HeatShields & Sun Reflectors

Cockpit Heatshields are interior sunshades for the aircraft's cockpit. The product is a unique composite of closed-cell foam with a silver mylar finish. The semi-rigid design is stiff enough to stand inside the window framing. Darts and folds are incorporated into the material so that it conforms to the complex shape of the helicopter windows. The set folds up flat and is easily stored in the included storage sleeve. Some designs may require velcro and suction cups. A Heatshield is an excellent short-term remedy for cockpit overheating, but an external fabric cover is more effective for long-term protection.

Heatshields are interior sunshades for an aircraft's windows or canopy glass. The product is a unique composite of closed-cell foam with a silver mylar finish. The semi-rigid design is stiff enough to stand along the inside of the windshield using sun visors or window framing. It folds up flat and easily stores in the included storage sleeve. Some designs may require velcro and suction cups. A Heatshield is an excellent short-term remedy for cockpit overheating.

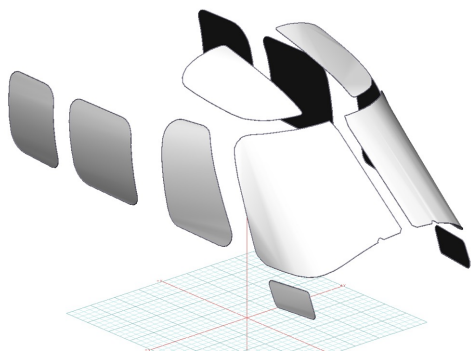

Agusta Grand HeatShields, 3D model



Agusta AW109S/SP Grand Heatshield Set

Description	Part Number	Price
HEATSHIELD SET (set of 12)	MH68-900	Contact Us
WINDSHIELD, FWD SIDE & SKYLIGHT HEATSHIELDS (set of 6)	MH68-901	Contact Us
SKYLIGHT HEATSHIELDS (set of 2)	MH68-910	Contact Us

Section 7: Light Weight Products: Travel Covers and FlyAway Covers

The **Agusta MH-68A, Sting Ray Lightweight Travel Bubble Cover** is the same design as our standard bubble cover, but the material used is very lightweight and will fold up and store in a smaller space.

Travel Covers are made with Silver Solution-Dyed Polyester fabric and fully lined over the entire cover. The material is lightweight and more compact for easy stowage in the aircraft. The polyester material is water resistant, but only intended for occasional use outside. We also have an ultra lightweight material available for fitted hangar dust covers. For daily outdoor use, the non-travel Sunbrella Cover is the best choice.



Agusta 109 Bubble, Rotor Hub & Blade Covers (illustration)



Agusta 109 Mk II+ Bubble Cover and Blade Tie-downs

Description	Part Number	Price
TRAVEL COVER, Light Weight Travel Bubble Cover	MH68-800	Contact Us
TRAVEL COVER, Light Weight Travel Bubble Cover w/Wire Strike	MH68-810	Contact Us
TRAVEL COVER, Light Weight Travel Windshield Cover	MH68-820	Contact Us

Prices subject to change. Other Covers and Design Alterations: Prices on request.

Prices are FOB Morgan Hill, CA. Sales tax on orders shipped to California addresses. Orders take approximately 3 weeks to complete. For domestic orders we normally ship by UPS ground service. Next day shipping and air parcel post is available on request. We can take payment by Visa, Mastercard, American Express, or Discover.

Bruce's Custom Covers offers protective covers and plugs for virtually every type of airplane, jet and helicopter. If you have questions about our products please call any time TOLL FREE: 800/777-6405, or FAX: 408/738-2729.



A division of Aircraft Covers, Inc.

18850 Adams Ct.
Morgan Hill, CA 95037
www.AircraftCovers.com

Aircraft Cover Ordering Form

Customer Info	Name _____ Shipping Address _____ _____ Phone & Email _____
Payment	Credit Card Number <input type="text"/> <input type="text"/> <input type="text"/> <input type="text"/> <input type="text"/> <input type="text"/> <input type="text"/> <input type="text"/> <input type="text"/> <input type="text"/> <input type="text"/> <input type="text"/> <input type="text"/> <input type="text"/> <input type="text"/> <input type="text"/> <input type="text"/> Exp. Date <input type="text"/> <input type="text"/> / <input type="text"/> <input type="text"/> V-Code* <input type="text"/> <input type="text"/> <input type="text"/> <input type="text"/> <small>*Visa, Mastercard, Discover: last 3 numbers on back of card, right of signature. Amex: 4 smaller numbers printed on face of card.</small>
A/C Info	Reg / Tail Number: _____ Aircraft Type: _____ Year: _____ Colors / Paint Scheme (be specific): _____

Please specify below the items you would like to order.
See technical sheet or visit our website for part numbers (or just fill in the description)

	Part Number	Quant	Description	Price
1				
2				
3				
4				
5				
6				
7				
8				
9				
10				

Optional Items (check the box of the item you want)

Imprint aircraft registration number onto both sides of canopy cover.....\$35.00

Imprint aircraft registration number onto jet intake covers.....\$55.00

TOTAL